



Horizontal Tempering Glass S.A.R.L.

Mkalles, Jisr El Bacha, Mar Elias Str.

H.T.G. Building, Beirut, Lebanon

T +961 (1) 683 074

Mob: +961 (3) 258 717

F +961 (1) 683 075

info@htempglass.com

www.htempglass.com





**WATERPROOF  
CURTAIN GLASS**  
NO NEED TO SUIT UP!



## INTRODUCTION

HORIZONTAL TEMPERING GLASS is one of the leading glass processing factories operating in Lebanon and the MENA region.

Founded in 1995 the company has evolved from a small scale glass tempering plant to a leader in manufacturing and supplying superior quality of different glass products ranging from annealed, tempered, laminated, bullet proof and double glazed glass units.

### Primary Objectives:

- Improve production quality through strict devotion to international standards and quality control measures.
- Precise and quick delivery service
- Sustain customer satisfaction, by providing good quality products and well managed customer services, through a qualified staff of professionally trained technicians, engineers and production control officers while abiding by the ISO 9001:2008 standards.
- Our team of engineers, production officers, department managers, operators and our top of the line equipments and machinery from major glass machines producers worldwide (Tamglass, Lisec...) favors accomplishments of all objectives HTG aims for.

To conclude, we at HTG believe in the saying:  
***"A satisfied customer is the best business strategy of all."***

**Antoine Hajjar**  
Partner

**Ibrahim Maalouf**  
Partner

## VISION

"Our vision is to be the leader in glass processing and distribution in the MENA region, as well as the subcontractor of choice for high end projects in the construction industry"

## MISSION

"We deliver our vision by ensuring total customer satisfaction through the provision of top quality products, just in time delivery and outstanding customer service."



## ISO CERTIFICATE

**Certificate**

Standard **ISO 9001:2008**

Certificate Registr. No. 01 100 051328

TÜV Rheinland Cert GmbH certifies:

Certificate Holder:   
**HORIZONTAL TEMPERING GLASS SARL**  
Mkalles, Jisr El Bacha  
St. Elie Church Street – HTG Bldg  
Beirut  
Lebanon

Scope: Glass processing factory; supplying and installing the glass

An audit was performed, Report No. 051328. Proof has been furnished that the requirements according to ISO 9001:2008 are fulfilled.  
The due date for all future audits is 22-12 (dd.mm).

Validity: The certificate is valid from 2013-01-23 until 2016-01-22.

2013-01-23   
TÜV Rheinland Cert GmbH  
Ahl Grauen Stein • 51105 Köln

  
DGA-ZM-58-95-00

 **TÜVRheinland**  
Precisely Right.

www.tuv.com

## QUALITY POLICY

The established policy of H. T. G. is to provide our customers with products and services that satisfy their needs and expectations in terms of quality, service, price, and delivered in conformance with the company's quality specifications or as laid down by the customer.

Throughout the continuous improvement of our products and processes, we aim to deliver to our customers products and services with zero defects fit for use matching the quality standards set by our management.

H. T. G. commits itself to continuous improvement, further expanding and increasing its competitive leadership in quality, cost and services in a joint partnership with their shareholders, employees, suppliers and customers.

The company's quality system is in accordance with the requirements of ISO9001:2008(expected certification date October 2012) and is considered to be the minimum standard set to be achieved by the company to ensure that the requirements of our customers are adhered to in all respects.

The quality procedures are mandatory and no deviations or alternatives are permitted. All the company's employees, whether directly involved with product quality or not, must comply with them and work through the policy set.

The Quality Department has been given the responsibility and authority to ensure that this policy is established, enacted correctly, implemented and that the quality system is periodically reviewed to improve its suitability and effectiveness.

It is our belief that a quality conscious company will build on its own reputation: therefore, a program of controlled quality is operated from day one that is receiving quality sensitive materials, all through the process in production till the final phase of dispatching the goods to our customers.

Each employee is made aware, and through continuous extensive training, of the need to improve performance and workmanship wherever and whenever possible in order to produce and provide the best quality products and services. This is reflected in job descriptions and operating procedures in addition to the support and encouragement given by immediate superiors.

In the End of the day, our policy and processes are reduced into one simple sentence:  
"A satisfied customer is the best business strategy of all"



General Manager: Ibrahim Maalouf  
Signature:



Date: 27/03/2012

## LOCATION

Mkalles, Jisr El Bacha, Mar Elias Str.  
H.T.G. Building, Beirut, Lebanon  
T +961 (1) 683 074 - +961 (1) 696 902  
Mob: +961 (3) 258 717  
F +961 (1) 683 075  
balconies@htempglass.com  
www.htempglass.com

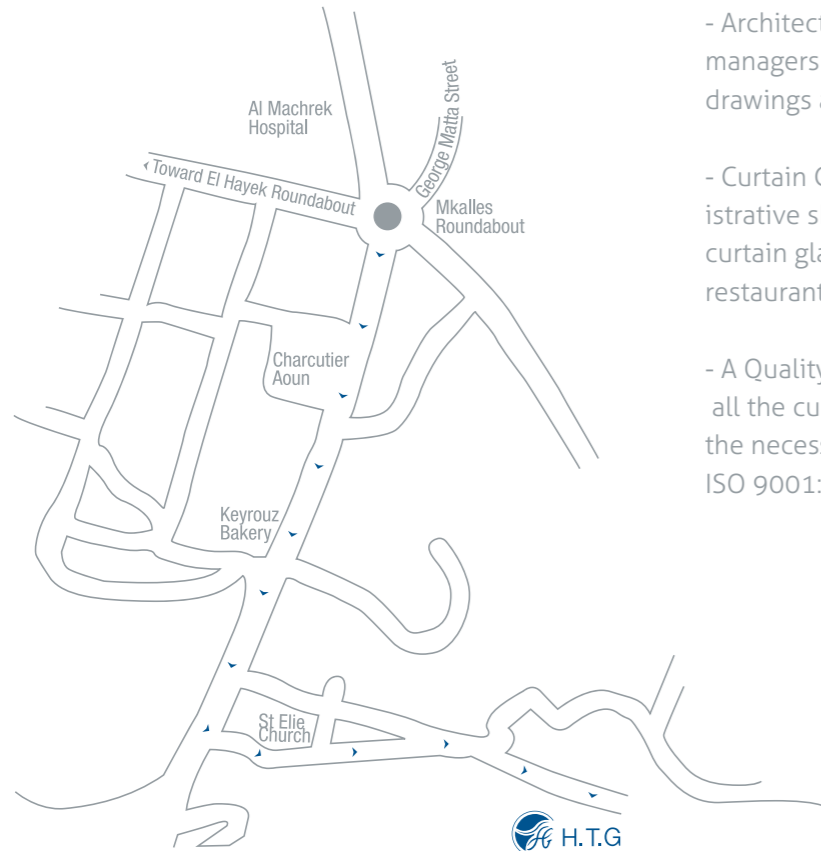

## STAFF

- 150 skilled workers and trained personnel operating in a 5500 m2 factory on different machines and glass processing phases.
- Several Technical Teams operating on sites executing glass works in different projects.
- Architectural Department where architects and project managers are responsible for designs, studies, shop drawings and project executions.
- Curtain Glass Department: Technical teams and administrative skilled people responsible for the execution of curtain glass systems for balconies, terraces, restaurants...
- A Quality team well trained and prepared to handle all the customer requirements and needs by providing the necessary service and product while meeting the ISO 9001:2008 regulations.





## WHY HTG?

- We as HTG gain our advantage as glass curtain installers by being the only ones that are fully equipped with a glass processing factory.
- We are the only certified glass processing factory in the country and the neighboring regions.
- We provide the slimmest curtain glass profile available in the market.
- Our products are rigid, maintenance free and lifetime guaranteed heavy duty products.
- Any suitable required aluminum RAL color can be provided
- We tend to install nothing less than tempered glass in our curtain glass system providing the highest factors of safety required for houses.

## THE SYSTEM

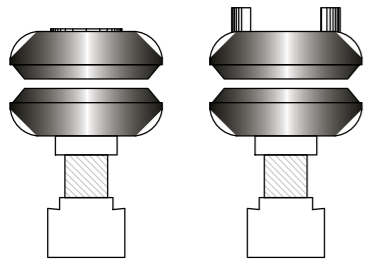

Small Wheel Big Wheel

Stainless Steel (grade 316) wheels covered with hard plastic coverings. Allows easy movement of the glass making it sound proof.

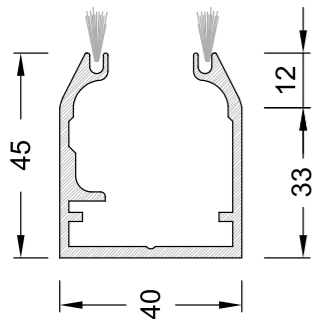

Brushes on both sides of our aluminum rails provide better proofing for both the water and wind exposures.

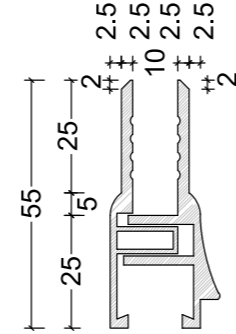
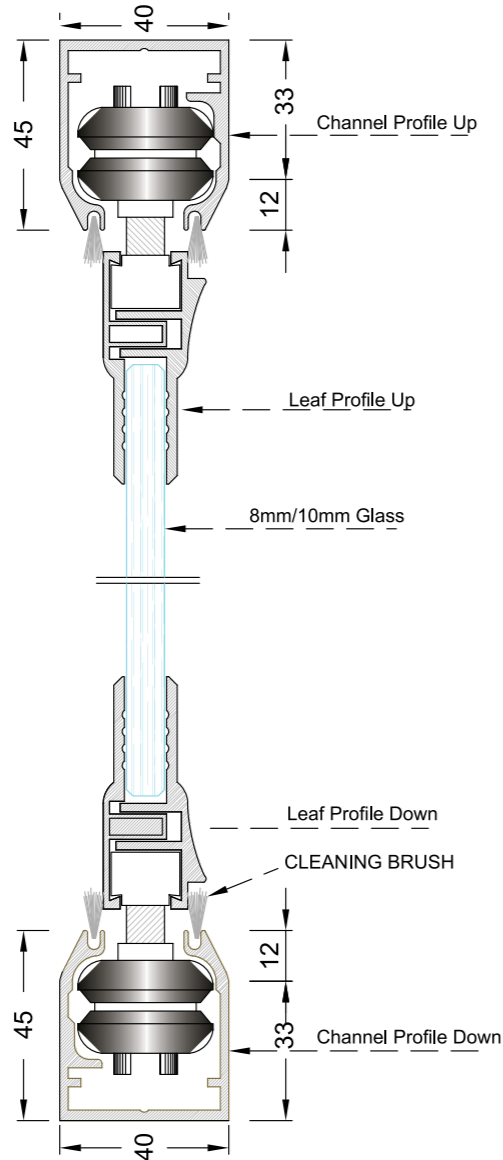

The curves that form our aluminum profiles make sure that every drop of water sliding on the glass remains out.

Having a panoramic view means less aluminum and more glass. Our 10.2cm profile provides us with the slimmest profile available in the market.

## HOW TO MAINTAIN THE SYSTEM

What makes our curtain glass system special and successful is its simplicity and being very user friendly.

Having all our accessories and parts made of stainless steel grade 316, prevents the corrosion from occurring and therefore the movement of the panels remains very easy.

The inward opening of the leaves allows easy cleaning of the glass when needed.

We will require no specific actions from our customers after the installation and the instructions given, therefore the systems' maintenance would be only of our concern.



**OUR PROJECTS**



ALL FOUR SEASONS IN ONE VIEW whether it is in your house, your coffee shop or restaurant, our system provides you with a better use of your extra space all throughout the seasons.

Broaden your horizons by inviting the outdoor sceneries into your living space and create extra spaces by expanding your balcony or terrace!



Harissa Restaurant  
Location: Harissa



Majed Costantine Building  
Location: Antelias



OUR PROJECTS



Bahri Gardens Project  
Location: Ramlet El Bayda



George Jabra Building  
Location: Dbayeh



Sunset Hotel  
Location: Maamelten



Salim Khalil Building  
Location: Badaro

